

## VLV-GF

### SQUARE FRONT GLASS GELATO DISPLAY

#### DESCRIPTION OF STANDARD UNIT:

- Forced cooling
- LED lighting
- Construction of powder coated steel
- Wooden casing
- Front and Side with glasses
- Finishes: Silver
- Warm white lighting
- Sliding plexi rear doors
- Forced cooling
- Temp. range\* : -12 ÷ -24 °C
- Automatic water Evaporation
- Digital temperature control
- Automatic defrost (system hot gas)

#### OPTIONS:

- Refrigerated version for pastry & chocolate
- Dry, non refrigerated version (room temperature)
- Wheels
- For individual decoration
- Highlighted front



MODEL	LENGTH	DEPTH	HEIGHT	QTY OF PANS	WEIGHT (LBS / KG)	ELECTRICAL
VLV10-GF	53 3/4"	31 3/4"	46 1/8"	10	485 / 220	115V / 60Hz / 1ph / 13.5 AMP

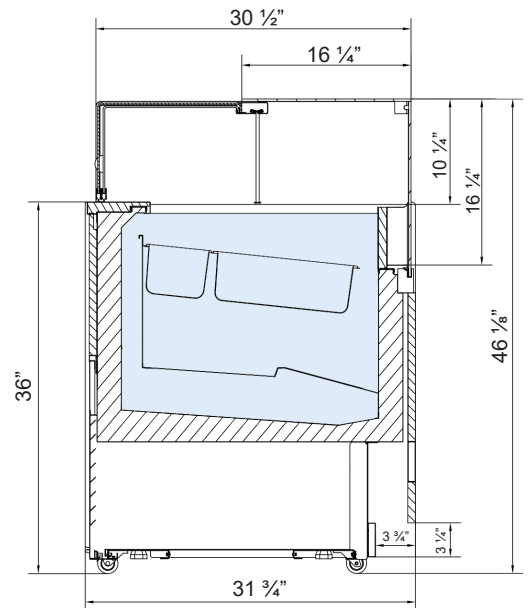

\* Temperature range given for max ambient temp of +30°C and relative humidity of 55%.  
 \*\* Cooling power demand: 400 W/1mr at evaporating temp. -10°C (Hawana W); 350W/1mr at evaporating temp. -25°C  
 \*\*\* We reserve the right to modify or change the technical specifications of the product without prior notice.



#### Profile Colors



RAL 9006  
White  
Aluminium

#### Wood Stains

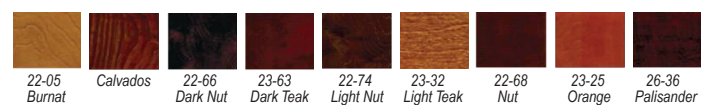

#### Available Colors

