

PL-RCC

REFRIGERATED CASH-OUT COUNTER

DESCRIPTION OF STANDARD UNIT:

- Construction of powder coated steel
- LED lighting
- Stainless steel exposition drawer
- Wooden casing
- Forced cooling
- Temp. range* : 0 ÷ +4°C
- Automatic water Evaporation
- Front glass secured by string cable
- Front opening glass
- Digital temperature control



OPTIONS:

- Color of your choice
- Wheels
- Ultrasonic humidifier

* - Values are provided for an ambient temp of +25°C and relative humidity of 60%.
 ** - Cooling power demand: 1000 W/1mr at evaporating temp. -10°C.

SPECIFICATIONS					
MODEL	LENGTH	DEPTH	HEIGHT	WEIGHT (LBS / KG)	ELECTRICAL
PL1-RCC	35 1/2"	36 1/2"	35 1/2"	176 / 80	115V / 60Hz / 1ph / 6 AMP
PL2-RCC	39 1/2"	36 1/2"	35 1/2"	242 / 110	115V / 60Hz / 1ph / 7 AMP

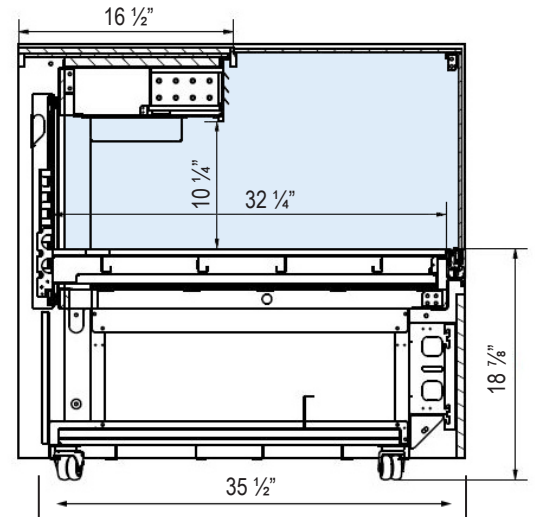

Profile Colors

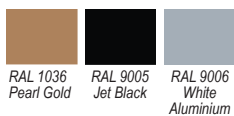

Granite Finishes

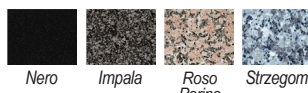

Wood Stains

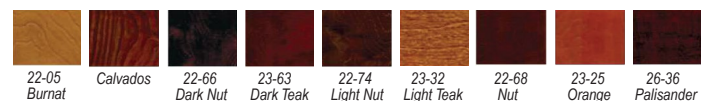

Available Colors

