

## HWM-RD

REFRIGERATED DISPLAY COUNTER  
DUAL COIL | DOUBLE CURVED GLASS

### DESCRIPTION OF STANDARD UNIT:

- Double gravity coil
- LED Market lighting
- Double front and side glass
- Construction of powder-coated steel
- ABS sides
- Front made of powder-coated steel
- Chrome bumper
- Stainless steel worktop
- Stainless steel storage chamber
- Heater under evaporator
- Heated Aluminum glass profile
- Temp. range\* : 0 ÷ +4 °C
- Automatic water evaporation
- Front opening glass
- Digital temperature control

### OPTIONS:

- For external condensing unit
- Fish version (FISH)
- Multiplexing
- Shelf
- Two levels exposition trays
- Stainless steel shelf for customer
- Wheels
- Back work top

Option: Work Top

Option: Shelf

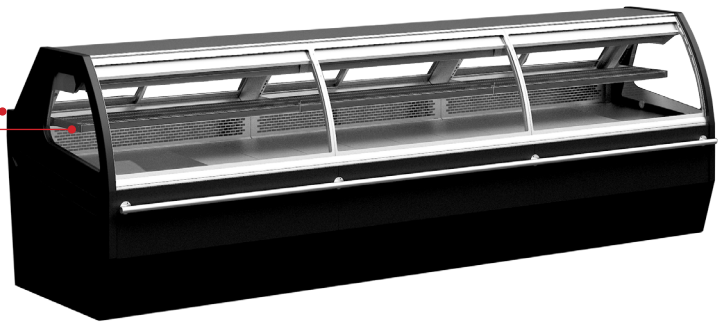
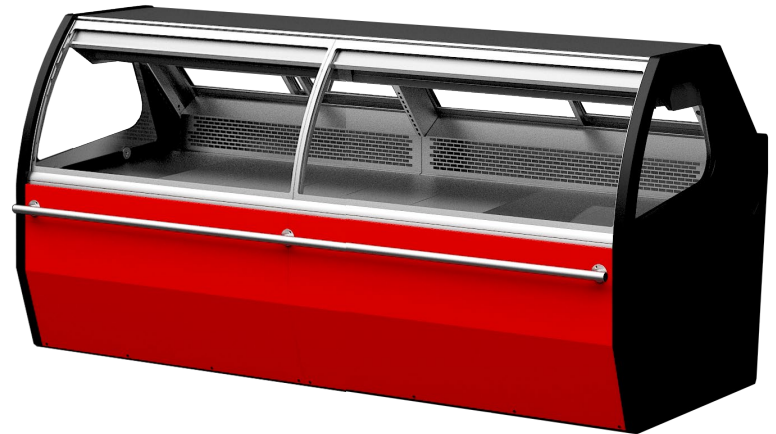

\* Temperature range given for max ambient temp of +25°C and relative humidity of 60%.  
\*\* Cooling power demand: 400 W/1mr at evaporating temp. -10°C (F); 350W/1mr at evaporating temp. -25°C (G).

SPECIFICATIONS					
MODEL	LENGTH	DEPTH	HEIGHT	WEIGHT (LBS / KG)	ELECTRICAL
HWM4-RD	52 3/4"	45 1/8"	49 1/4"	551 / 250	115V / 60Hz / 1ph / 8.5 AMP
HWM8-RD	101 1/2"	45 1/8"	49 1/4"	871 / 395	115V / 60Hz / 1ph / 10.5 AMP
HWM12-RD	151 1/2"	45 1/8"	49 1/4"	1259 / 571	115V / 60Hz / 1ph / 13.5 AMP

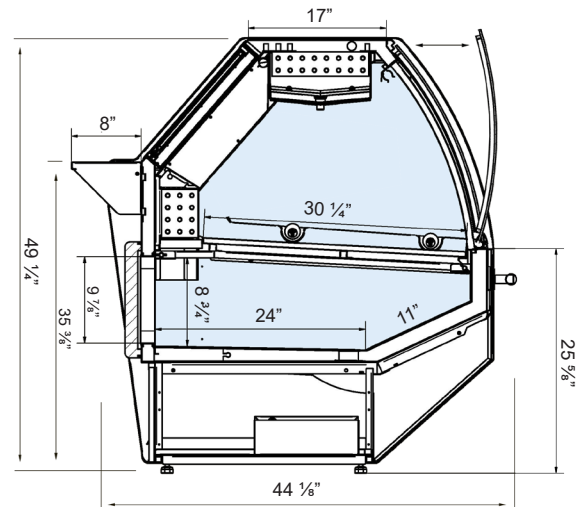

### Available Colors

