

EXP-IFCR REMOTE | DUAL TEMP FREEZER | REFRIGERATOR ISLAND BUNKER

DESCRIPTION OF STANDARD UNIT:

- Forced cooling
- Automatic defrosting
- Display made of galvanized steel
- Double glazed sides
- LED lighting, white
- Temp. range*: 0 ÷ +4 °C Refrigerator
- Temp. range*: -12 ÷ -22 °C Freezer
- Automatic water Evaporation
- Digital temperature control
- Cabinet on wheels with a brake



Available with top sliding doors

OPTIONS:

- Freezer or Refrigerator
- Version for external condensing unit (AZ)**
- Colors

SPECIFICATIONS					
MODEL	L	D	H	WEIGHT (LBS / KG)	ELECTRICAL
EXP6-IFCR	74 3/4"	37 1/2"	35 7/8"	783 / 355	220V / 60Hz / 1ph / 4 AMPS
EXP8-IFCR	98 1/2"			1029 / 467	220V / 60Hz / 1ph / 6 AMPS

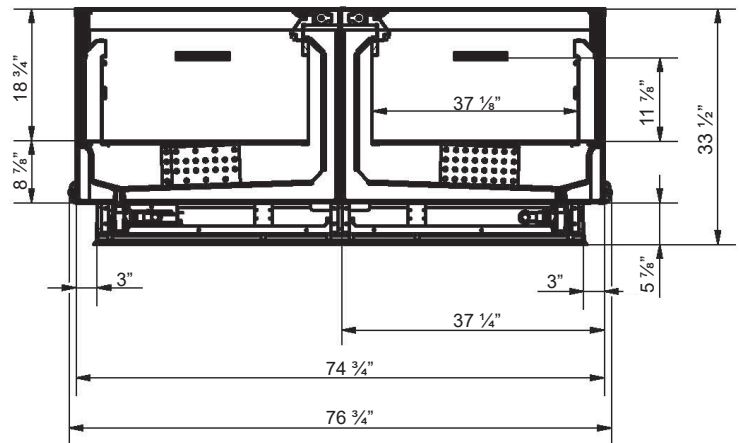
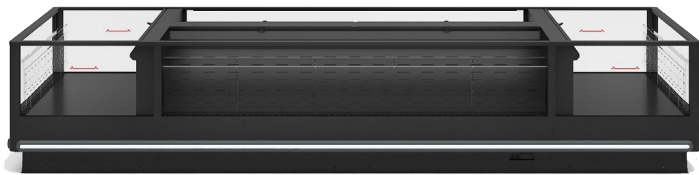
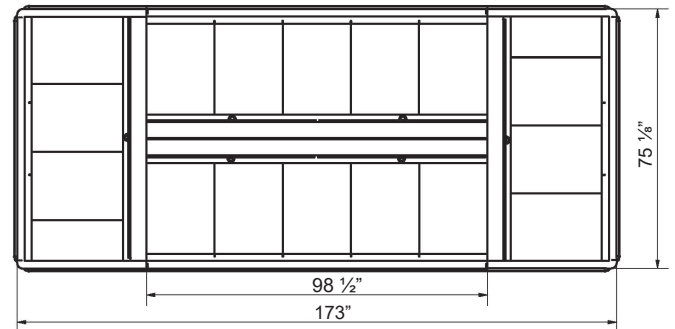

Temperature range given for maximum ambient temperature of +25°C and relative humidity 60%.
 ** Cooling power demand: 1200 W/1m³ at evaporating temp. -10°C. Automatic water evaporation on request.
 ** Values are provided for an evaporation temp. of -10 °C, condensation temp. of +45°C, ambient temp of +25°C and relative humidity of 60%.

- Perfect for impulse selling
- Good visibility of goods
- Accessories for an attractive presentation of frozen food
- Island available in cooling, freezing and dual temp.

Available Colors

