

CM-WRP

CURVED FRONT GLASS REFRIGERATED DISPLAY CASE

DESCRIPTION OF STANDARD UNIT:

- 3 versions: Refrigerated (CM-R), Hot (CM-H), Dry (CM-D)
- LED lighting
- Construction of powder coated steel
- Wooden casing
- Side and front glasses: double with serigraphy (golden, silver or black)
- Finishes: golden, silver or black
- 3 rows of highlighted adjustable shelves: glass (CM-R, CM-D) or stainless steel (CM-H)
- Yellow lighting
- Sliding, double glass rear doors
- Forced cooling
- Temp. range* : 0 ÷ +4°C
- Automatic water Evaporation
- Hygrostat (humidity reduction)
- Front glass secured by string cable
- Front opening glass
- Digital temperature control



OPTIONS:

- Version for chocolate & pralines
- Hot unit, Temp. range* : +40 ÷ +90°C
- Dry non refrigerated version (room temperature)
- For external condensing unit
- Wheels
- Ultrasonic humidifier
- Stainless steel worktop
- Thermometer in the lamp
- For individual decoration
- Multiplexing
- Flap doors on the front
- Highlighted front

* - Values are provided for an ambient temp of +25°C and relative humidity of 60%.
 ** - Cooling power demand: 1000 W/1m³ at evaporating temp. -10°C.

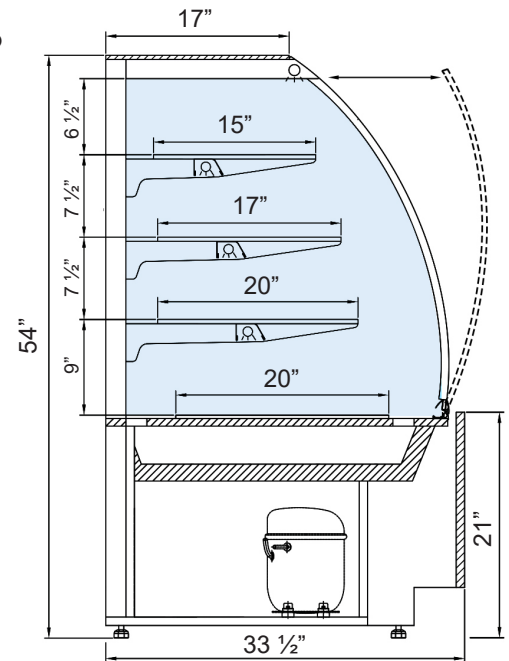

SPECIFICATIONS					
MODEL	LENGTH	DEPTH	HEIGHT	WEIGHT (LBS / KG)	ELECTRICAL
CM2-WRP	25 1/4"	33 1/2"	54"	339 / 154	115V / 60Hz / 1ph / 8 AMP
CM3-WRP	37 1/8"	33 1/2"	54"	509 / 231	115V / 60Hz / 1ph / 9.5 AMP
CM4-WRP	53"	33 1/2"	54"	677 / 307	115V / 60Hz / 1ph / 11.5 AMP



Profile Colors

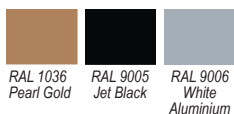

Wood Stains

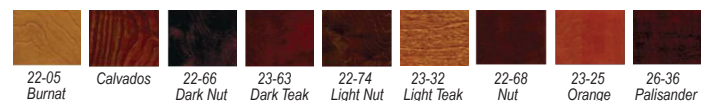

Available Colors

